

353376-3 ✓ ACTIVE

AMP | AMP Auto Squib Products

TE Internal #: 353376-3

Automotive Terminals, Socket, Pin Diameter .039 in [1 mm], 22 – 20

AWG Wire Size, .3 – .5 mm² Wire Size, AMP Auto Squib Products

[View on TE.com >](#)



Terminals & Splices > Automotive Terminals

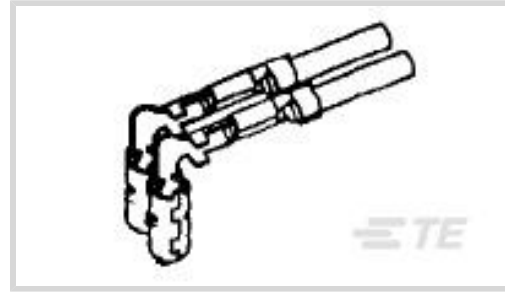

Terminal Type: **Socket**

Mating Pin Diameter: **1 mm [.039 in]**

Terminal Transmits: **0 – 24 A (Low Power)**

Wire Size: **.3 – .5 mm²**

Features

Product Type Features

Receptacle Style	90°
Sealable	No

Contact Features

Contact Size	1mm
Contact Fabrication	Stamped & Formed
Crimp Type	F-Crimp
Terminal Type	Socket
Mating Pin Diameter	1 mm [.039 in]
Interface Plating	Gold (Au)
Contact Termination Area Plating Material	Tin (Sn)

Termination Features

Termination Method to Wire & Cable	Crimp
Product Terminates To	Wire

Dimensions

Wire Size	.3 – .5 mm ²
Wire Size Search	20 AWG, 21 AWG, 22 AWG
Wire Insulation Diameter	1.4 – 1.7 mm

Usage Conditions

Insulation Option	Uninsulated
-------------------	-------------



Operating Temperature (Max)	80 °C[176 °F]
Operating Temperature Range	-30 – 80 °C[-22 – 176 °F]

Operation/Application

Compatible With Wire Base Material	Copper
------------------------------------	--------

Packaging Features

Packaging Method	Reel
Packaging Quantity	4000

Other

Terminal Transmits	0 – 24 A (Low Power)
--------------------	----------------------

Product Compliance

For compliance documentation, visit the product page on [TE.com](https://www.te.com)>

EU RoHS Directive 2011/65/EU	Compliant
EU ELV Directive 2000/53/EC	Compliant
China RoHS 2 Directive MIIT Order No 32, 2016	No Restricted Materials Above Threshold
EU REACH Regulation (EC) No. 1907/2006	Current ECHA Candidate List: JUNE 2022 (224) Candidate List Declared Against: JUNE 2022 (224) Does not contain REACH SVHC
Halogen Content	Low Halogen - Br, Cl, F, I < 900 ppm per homogenous material. Also BFR/CFR/PVC Free
Solder Process Capability	Not applicable for solder process capability

Product Compliance Disclaimer

This information is provided based on reasonable inquiry of our suppliers and represents our current actual knowledge based on the information they provided. This information is subject to change. The part numbers that TE has identified as EU RoHS compliant have a maximum concentration of 0.1% by weight in homogenous materials for lead, hexavalent chromium, mercury, PBB, PBDE, DBP, BBP, DEHP, DIBP, and 0.01% for cadmium, or qualify for an exemption to these limits as defined in the Annexes of Directive 2011/65/EU (RoHS2). Finished electrical and electronic equipment products will be CE marked as required by Directive 2011/65/EU. Components may not be CE marked. Additionally, the part numbers that TE has identified as EU ELV compliant have a maximum concentration of 0.1% by weight in homogenous materials for lead, hexavalent chromium, and mercury, and 0.01% for cadmium, or qualify for an exemption to these limits as defined in the Annexes of Directive 2000/53/EC (ELV). Regarding the REACH Regulation, the information TE provides on SVHC in articles for this part number is based on the latest European Chemicals Agency (ECHA) 'Guidance on requirements for substances in articles' posted at this URL: <https://echa.europa.eu/guidance-documents/guidance-on-reach>

Compatible Parts



TE Part # 2305570-1
Strip Terminal Cutter-Side Feed-No Crimp

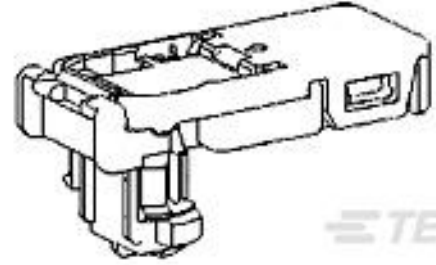

TE Part # 1376688-1
11DIA SQUIB SLIM PLUG HSG YELL



TE Part # 353377-7
SQUIB CONN HSG YELLOW

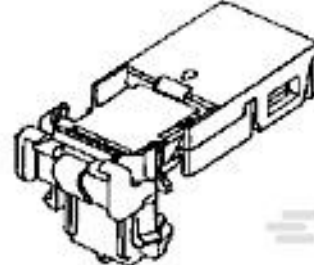

TE Part # 1612120-3
11DIA SQUIB SLIM MK-2 PLUG HSG

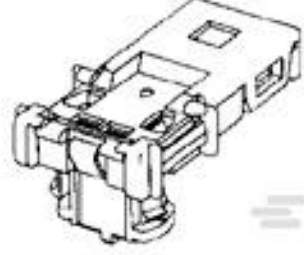

TE Part # 1473139-1
SQUIB 11DIA MK-2 PLUG HSG

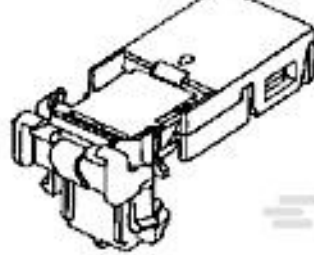

TE Part # 1612120-1
11DIA SQUIB SLIM MK-2 PLUG HSG

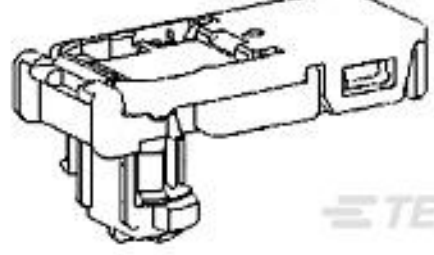

TE Part # 1376688-3
11DIA SQUIB SLIM PLUG HSG ORNG

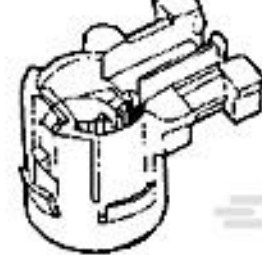

TE Part # 353744-7
SQUIB AIRBAG/HSG-MAIN



TE Part # 2-2151198-1
OCEAN_2.0_Applicator-S-070F070F



TE Part # 2-2151198-2
OCEAN_2.0_Applicator-S-070F070F



TE Part # 2151198-1
OCEAN_2.0_Applicator-S-070F070F



TE Part # 2151198-2
OCEAN_2.0_Applicator-S-070F070F



TE Part # 7-2151198-1
OCEAN_2.0_Applicator-S-070F070F



TE Part # 7-2151198-2
OCEAN_2.0_SPARE_PART_KIT-070F070F



TE Part # 7-2151198-7
OCEAN_2.0_SPARE_PART_KIT-070F070F



TE Part # 1376030-1
SQUIB CONN HSG IIDIA

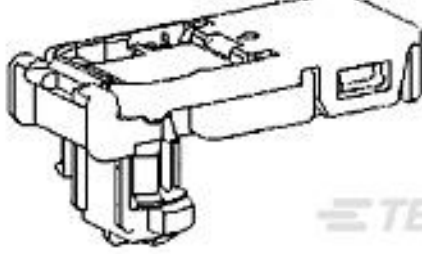

TE Part # 1376688-2
11DIA SQUIB SLIM PLUG HSG YELL



TE Part # 1-353380-7
SQUIB CONN RETAINER ASSY 2P

Also in the Series | **AMP Auto Squib Products**

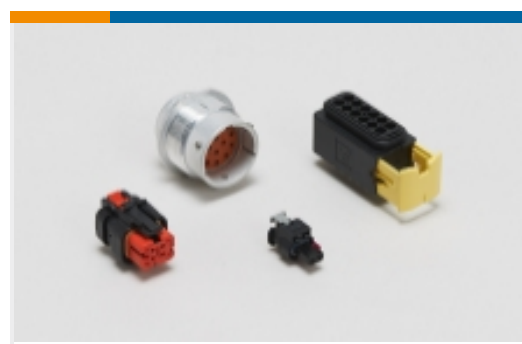

Automotive Housings(13)

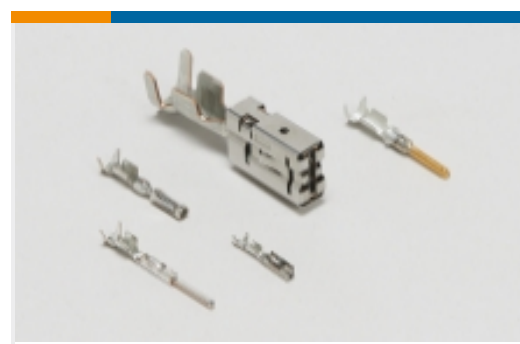

Automotive Terminals(2)

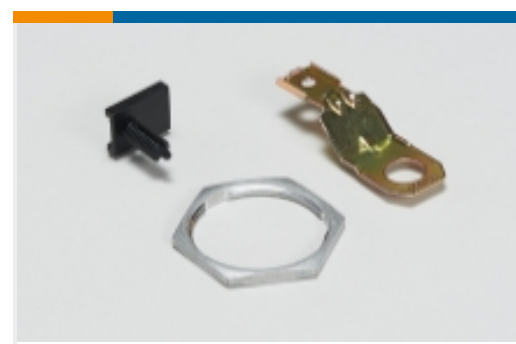
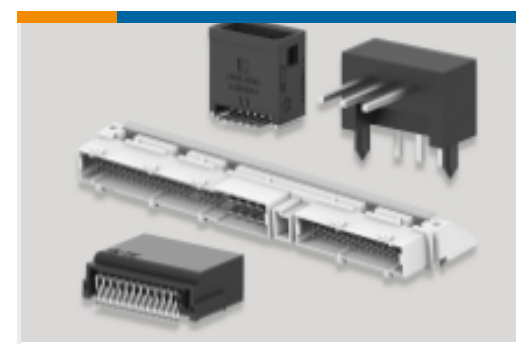
Other Automotive Connector
Accessories(8)

PCB Headers & Receptacles(1)

Documents

Product Drawings

SQUIB CONT 1MM PIN DIA SOCKET

Japanese

CAD Files

Customer View Model

[ENG_CVM_353376-3_B1.3d_igs.zip](#)

English

Customer View Model

[ENG_CVM_353376-3_B1.3d_stp.zip](#)

English

Customer View Model

[ENG_CVM_353376-3_B1.2d_dxf.zip](#)

English

3D PDF

English

By downloading the CAD file I accept and agree to the [Terms and Conditions](#) of use.

Product Specifications

11DIA SQUIB CONNECTOR SLIM TYPE MK-II

English

11DIA SQUIB CONNECTOR SLIM TYPE MK-II

English

Product Specification

Japanese

Product Specification

Japanese

Product Specification

English

SQUIB CONNECTOR

English

SQUIB CONNECTOR

English

Product Specification



English

[SQUIB Connector 11DIA](#)

Japanese

[Product Specification](#)

Japanese

[SQUIB Connector 11DIA](#)

Japanese

[Product Specification](#)

Japanese

[11DIA SQUIB CONNECTOR SLIM TYPE MK-II](#)

English

[11DIA SQUIB CONNECTOR SLIM TYPE MK-II](#)

English

[11DIA SQUIB CONNECTOR SLIM TYPE MK-II](#)

English

[11DIA SQUIB CONNECTOR SLIM TYPE MK-II](#)

English

[11DIA SQUIB CONNECTOR SLIM TYPE MK-II](#)

Japanese

[11DIA SQUIB CONNECTOR SLIM TYPE MK-II](#)

Japanese

[11DIA SQUIB CONNECTOR SLIM TYPE MK-II](#)

English

[11DIA SQUIB CONNECTOR SLIM TYPE MK-II](#)

English

[11DIA SQUIB CONNECTOR CHECKER](#)

English

[11DIA SQUIB CONNECTOR CHECKER](#)

Japanese

Product Environmental Compliance

[Product Compliance](#)

English

[Product Compliance](#)

English

Instruction Sheets

[Instruction Sheet \(non U.S.\)](#)

English

[Squib Connector](#)

English

[Instruction Sheet \(non U.S.\)](#)



Japanese

[Instruction Sheet \(non U.S.\)](#)

Japanese

[11dia squib connector checker](#)

Japanese

[Instruction Sheet \(non U.S.\)](#)

Japanese